



OWNER'S MANUAL



12k SuperGlide
(Part #3100)



14k SuperGlide
(Part #4100)



18k SuperGlide
(Part #4400)



24k SuperGlide
(Part #3600)

The following instructions provide valuable information regarding the function and proper use of the SuperGlide 5th wheel towing system.

YOU MUST COMPLETELY READ THE INSTRUCTIONS WITHIN THIS MANUAL PRIOR TO OPERATING THE HITCH TO PREVENT UNNECESSARY DAMAGE TO THE HITCH AND/OR YOUR VEHICLE.

TABLE OF CONTENTS

Note: Parts referenced in this document are labeled for identification in the drawings on pages 10 - 11.

<u>Index</u>	<u>Pg.</u>
Caution.....	3
Preparation / Maintenance.....	3
Before & During Each Trip.....	4
Monthly or After Long Storage Periods.....	4
Storage.....	4
5 TH Wheel Plate Operation.....	5
Universal Capture Plate Installation.....	6
King Pin Boxes Shorter Front to Back.....	7
Hitching.....	8
Unhitching.....	9
Adjusting The Turntable Cam Arm.....	10
Challenge vs. Solution.....	11
FAQ.....	12
12k Parts List.....	14
12k Exploded View Illustration.....	15
14k Parts List.....	17
14k Exploded View Illustration.....	18
18k Parts List.....	20
18k Exploded View Illustration.....	21
24k Parts List.....	23
24k Exploded View Illustration.....	24
3336 Conversion Adapter.....	25
Warranty Registration Form.....	26

CAUTION

- As a general rule, for the SuperGlide hitch to maintain proper clearance to the truck, the leading edge of the trailer (measured at the corner) should be even with the center of the king pin. Most truck trailer combinations will allow 102" wide trailers if the king pin is located as described. Narrower trailers will allow the king pin to be "tucked" under the trailer over hang to some extent (Figure 1). Call PullRite technical support with trailer width, make and year of truck and distance the king pin is from leading edge of the trailer (Dimension A). (800) 443-2307.

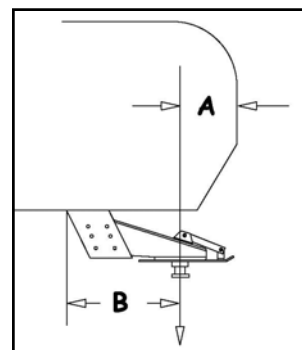

Figure 1

- 12K SuperGlide Owners — 2004-2005 Super Crew F-150 trucks have bed sides that are 2" deeper, make certain before installation that the trailer being towed has enough king pin box adjustment available so that the necessary side tilt clearance can be achieved.
- Using a trailer that has a long rear slope to the King Pin Box Hangar, "B" in (Figure 1), may cause damage to the trailer or truck bed during turns. Dimension "B" must be less than one half the width of the inside top edges of the bed.
- The SuperGlide hitch is equipped with a side-to-side pivot feature. There should be a minimum of 6" between the truck bed rails and the under side of the trailer for side tilt clearance. It is the customers responsibility to adjust the trailer king pin box for the appropriate amount of clearance depending on the terrain being traveled (example: some State Parks are sloped and unpaved; some driveways are steeply angled). If bed covers are added, care must be taken to allow for additional clearance.
- The SuperGlide hitch is designed to allow you to make a 90 degree turn. Please use extreme caution when turning this far. In addition to putting stress on the wheels and axles of your trailer, if you make a turn greater than 90 degrees the trailer will contact your truck and you WILL damage various parts of the hitch which will NOT be covered under the manufacturers warranty.
- Position your brake cable so the slack in the cable will not be allowed to catch on the hitch during turns. Failure to modify its length may cause the cable to catch on protruding parts of the hitch which could activate the trailer brake, causing damage to the truck, trailer or hitch. Resulting damages will not be covered by warranty.

PREPARATION / MAINTENANCE

(READ THIS SECTION COMPLETELY BEFORE OPERATING YOUR HITCH. IF YOU HAVE ANY QUESTIONS, PLEASE CONTACT CUSTOMER SERVICE AT (800) 443-2307 BEFORE CONTINUING.

IMMEDIATELY AFTER INSTALLATION

1. **As of December 2006, SuperGlide hitches are no longer shipped with factory grease applied to the way tubes. If grease is present from hitches built prior to 12/2006, you must clean off all factory grease from the way tubes (WD-40 works great as a cleaning agent) and reapplied before towing. See details under "BEFORE and DURING EACH TRIP" on page 4, #2.**
2. Hook up to your trailer following the instructions on pages 6-7.
3. Testing Clearance—When you are assured your trailer is safely hooked up, pull forward and slowly start to turn. Make sure that someone is outside watching the distance between the cab and the trailer. The distance between the cab and trailer should be greater than two inches at all points of the turn. Specifically watch the distance when the corner of the trailer is closest to the cab and also when nearing a 90 degree turn. The minimum two inches of clearance is needed for normal driving conditions. The practice of testing clearance will let you know how much clearance you actually have should you encounter adverse road conditions.

Example: It is possible for the trailer to hit the cab when turning through a dip where the corner of the trailer is closest to the cab or when nearing a 90 degree turn.

BEFORE AND DURING EACH TRIP

1. **5th WHEEL PLATE {A1}**: The plate and it's moving parts should be lubricated with a light lubricant such as WD-40, 3-in-1 oil, or Silicone Spray Lubricant, before each trip or as needed. Be sure the plate is free of dirt and old oil buildup. While holding the left and right edges of the 5th Wheel Plate {A1}, push the plate forward and backward to see if there is play between the lower Turntable Cam Arm {C1} and the Nylon Block {E1}. If you can feel or see any movement between the Turntable Cam Roller {C2} and the Nylon Block {E1} you should remove the play by following the procedure listed under " **TURNTABLE CAM ARM** " (pg. 8).
2. **WAYS/GLIDE TUBES {D1}**: The Ways (or Glide Tubes) should be **liberally** lubricated **each day of use**. **It is essential that you use a medium duty grease on top and inward facing sides of Way Tubes. WD-40 or Silicone spray is NOT sufficient.** We recommend using Slip Plate which can be ordered from your local distributor/dealer or direct from PullRite Towing Systems. ***Clean the old grease off as needed and reapply.*** Move the 5th wheel assembly back and forth during lubrication to spread the lubrication along the ways. This will also lubricate the turntable shaft. When your trip is completed, be sure there is still a coating of grease on the Ways to protect them while the hitch is not in use. **Failure to properly lubricate the Way Tubes WILL eventually cause galling between the metals of the Way Tubes and the Cam Arm Assembly which WILL result in the failure of the hitch to work properly. Destruction of some of the various hitch parts is also likely and will NOT be covered under the manufacturers warranty.**
3. **KING PIN**: Be sure the trailer KING PIN is clean and free from rust. A light coating of WD-40 or other similar lubricant should be used on the King Pin.
4. **TRUCK BED**: Anything carried in the bed of your truck during towing will need to be well secured. Remove anything that is not secured and any debris that might move around in the bed and contact the hitch. Be sure that the emergency cable is not too long and is secure (the trailer and hitch head move together so there is no reason for slack in the cable). **This will help to ensure that nothing will get caught in or jam the movement of the cam which can cause damage to the hitch.**

MONTHLY OR AFTER LONG STORAGE PERIODS

1. Inspect all mounting bolts (Base Mounting Bolts {G6}, and Post Holders {G4}) periodically for tightness and general condition.
2. Inspect and lubricate the Pivot Bolt {H4} monthly when heavily used (or annually with light usage). Lubricate with axle grease.
3. Remove the 5th Wheel Plate {A1}, and turn it over to inspect all moving parts for wear. Clean and lubricate with WD-40, 3-in-1 oil, or Silicone spray. Wipe off excess oil. Pull the Release handle repeatedly so that the lubricant will spread and may be applied to otherwise covered surfaces.

STORAGE

When storing the SuperGlide Hitch, you should be sure that the 5th Wheel Plate {A1} is covered with a light coating of oil, and that the Ways {D1} have a good coating of grease. Cover the whole assembly to prevent accumulation of dirt and grime

5TH WHEEL PLATE {A1} OPERATION

A better understanding of the plates locking and un-locking operation can be obtained by viewing the working parts from the underside of the plate. The 5th Wheel Plate {A1} can be removed and turned over to view the workings of the mechanism. Refer to the drawings in (Figure 2) for the parts identification.

1. To open the locking mechanism, lift and pull the Release Handle out until the Lock Catch engages the Lock Jaw Assembly. (see below).
2. As the trailer king pin moves into the plate, it will contact the Lock Lever, forcing the Lock Catch to disengage the Lock Jaw Assembly, allowing the Main Spring to close the Lock Jaw Assembly behind the King Pin (see below). The King Pin must be fully engaged in the plate slot or the Lock Jaw Assembly will not seat properly, and the Handle Catch would not then engage the inner side wall of the plate. To be certain that the Lock Jaw Assembly has closed fully, attempt to pull the Release Handle without first lifting it. To discourage theft or pranksters, place a padlock through the obround hole above the Release Handle.

CAUTION: DO NOT ATTEMPT TO TRIP THE LOCK MECHANISM WITH YOUR HAND. USE A PROBE DEVICE TO SIMULATE THE KING PIN ACTION

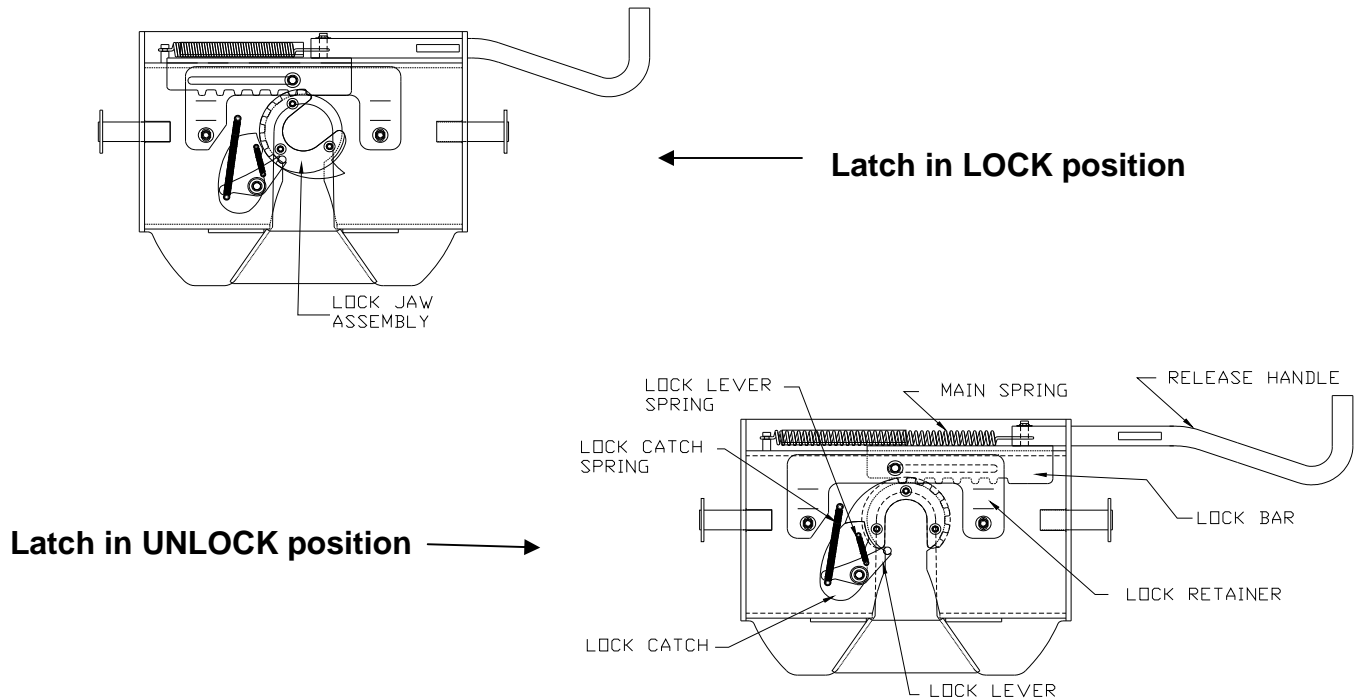
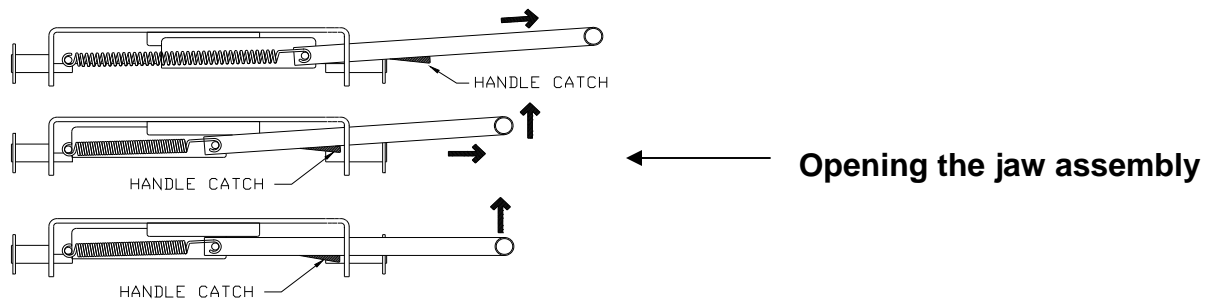

Figure 2



UNIVERSAL CAPTURE PLATE INSTALLATION

The following instructions should be followed to install the Universal Capture Plate. Note: If more information is needed, Please call PullRite at (800) 443-2307

NOTE: Quick Connect Capture Plates are available for various king pin box sizes. Contact the Customer Service Dept. at PullRite for further assistance.

NOTE: 10 bolts are required to fasten the Universal Capture Plate. Make certain they are positioned so the front row of holes have at least 2 to 3 fasteners, the rear row of holes has 2 fasteners and each outside row of holes has 2 to 3 as well. Fill in around the king pin. If you are not able to bolt into the outside perimeter, you will need to weld on extensions to the king pin plate, both front and rear. See instructions for "King Pin Boxes That Are Shorter Front To Back."

FOR KING PIN BOXES WITH A FLANGE: (Figure 3)

1. Place the Capture Plate {J2} over the King Pin, with the guide wedge towards the rear of the trailer (wedge facing down). Align the Capture Plate {J2} square with the king pin box and clamp in place to prevent movement.
2. Mark the holes for drilling through the Capture Plate {J2} onto the King Pin Box flange.
3. Remove the Capture Plate {J2} or use it as a guide and drill $\frac{1}{4}$ " holes through the flange.
4. Re-install the Capture Plate {J2} (as in step 1).
5. Use the $\frac{1}{4}$ " bolts provided, to secure the Capture Plate {J2} onto the king pin box flange. A **minimum of 10 bolts** must be used to fasten the plate on. For use with heavy trailers, more bolts will be needed to secure this plate. Make certain all the bolts are **flush with the trailer plate**. Fasteners that are installed at an angle catch and "drag" on the 5th wheel plate surface, weakening the integrity of the fastener.
6. If the Capture Plate {J2} extends beyond the King Pin box, then install the braces {K2-K4} as shown in Figure 4.

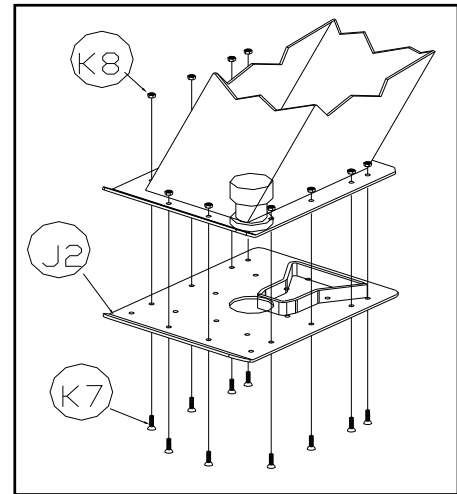

Figure 3

FOR KING PIN BOXES WITHOUT FLANGES: (Figure 4)

1. Place the Capture Plate {J2} over the King Pin, with the guide wedge towards the rear of the trailer (wedge facing down), and hold in place to prevent movement.
2. The Capture Plate {J2} can be secured to the King Pin Box sides by welding angle iron supports to the King Pin Box, or use the procedure in step 3. (Angle iron is not provided).
3. For the holes where you cannot reach the backside, drill holes with a #8 drill and tap with a $\frac{1}{4}$ "-20 tap.
4. If the Capture Plate {J2} extends beyond the King Pin Box, then install the Knee Braces as shown in Figure 4.
5. Install the Capture Plate {J2}, using the $\frac{1}{4}$ " bolts provided, to secure the Capture Plate {J2} onto the King Pin Box. A **minimum of 10 bolts** must be used to fasten the plate on. For use with heavy trailers, more bolts will be needed to secure this plate. The fasteners used in step 4 do not count as part of the minimum number of bolts required.

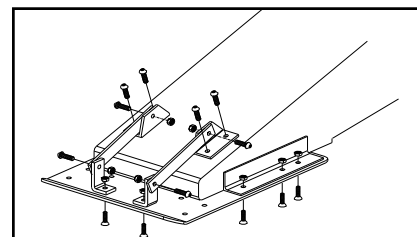

Figure 4

FOR KING PIN BOXES THAT ARE SHORTER FRONT TO BACK

1. Place the Capture Plate {J2} over the king pin, with the guide wedge towards the rear of the trailer (wedge facing down) and measure the distance from the front and rear of the king pin box to the respective edges of the Capture Plate {J2} (to the bend of the Capture Plate {J2} in the front). Referring to Figure 5 below, using the supplied extension plates, fasten plates to the front and back row of holes using the 1/4" bolts and lock nuts provided.
2. While the trailer plate is in position under the king pin box, clamp these plates to both the front and rear of the Capture Plate {J2}. Remove the Capture Plate {J2} and drill matching holes in the two support plates with a 1/4" bit using the Capture Plate {J2} as a guide.
3. Fasten the two support plates to the Capture Plate {J2} with the 1/4" Bolts {K7} and Lock Nuts {K8} provided.
4. Replace the Capture Plate {J2} on the king pin box, check for square alignment and **weld** the support plates to the king pin box.
5. Attach the Knee Braces {K2,3 & 4} to the king pin box and the Capture Plate {J2}. Braces {k2} may have to be welded on if the interior of the king pin box is not accessible.
6. See Figure 5 below for diagram and special notes.

CAUTION: The provided extension plates are universal and must be trimmed to fit your specific application. When extensions are installed, the capture plate adapter (#3317) should be flush against the bottom of the trailer's king pin plate.

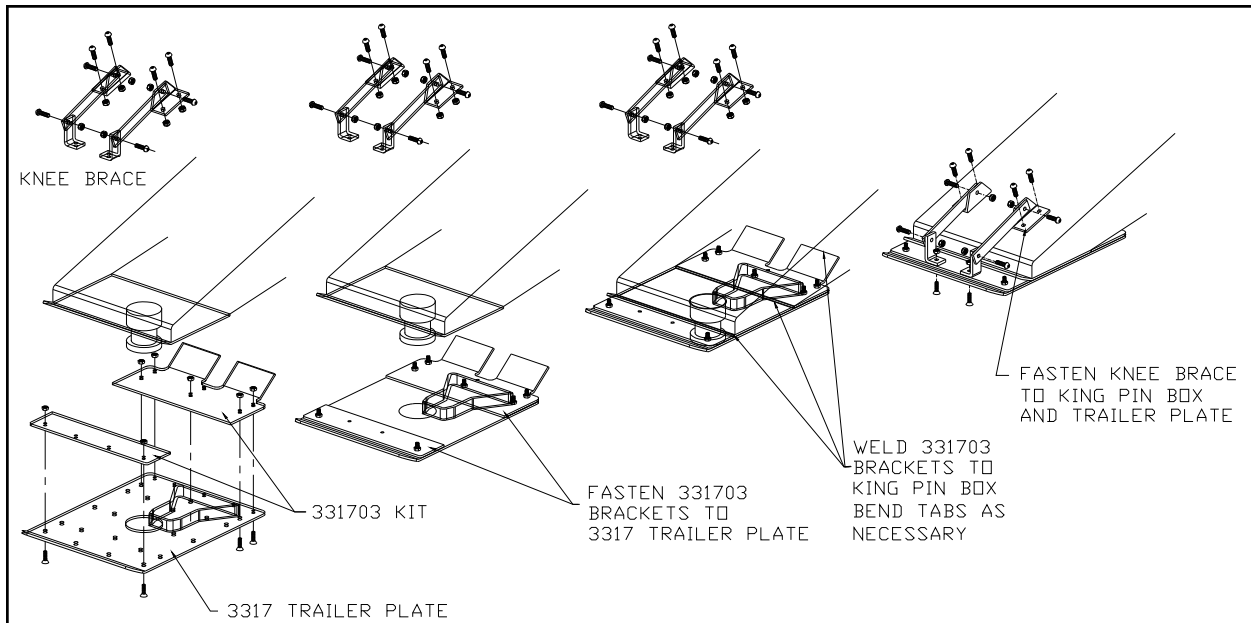

Figure 5

HITCHING

WARNING: Never perform any of the following actions while any part of a person is between the vehicle and trailer.

1. Align your truck with the center of the trailer. The truck should be close to parallel to the centerline of the trailer. Hitching can only be accomplished when the tow vehicle and the trailer are aligned within 16° of each other (**Figure 6**).
2. Block the trailer wheels so the trailer will not roll back.
3. Lower your tailgate and back up until there is about 6" of clearance between the SuperGlide hitch and the end of the Trailer Plate {J2}. Raise or lower the front of the trailer so the bottom of the Trailer Plate {J2} is aligned slightly above the beginning of the ramp area of the 5th wheel plate (**Figure 7**). This procedure will cause the front edge of the Trailer Plate {J2} to "ride up" the ramp and flatten or tilt the hitch plate into a parallel position.

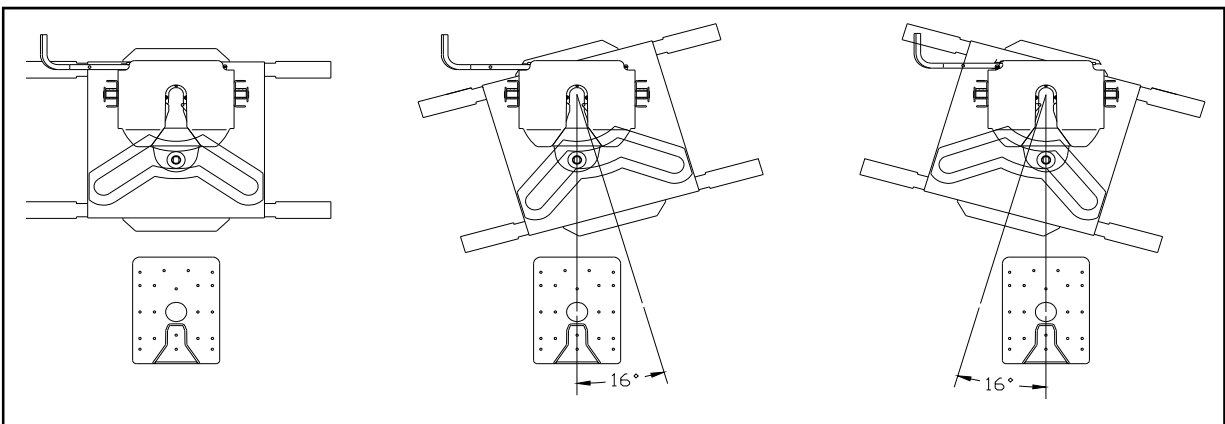

Figure 6

CAUTION: If this procedure is not followed, the king pin may bind in the plate mechanism and not lock-in properly. Following the procedure as outlined in Step 3 will ensure that you will not "high hook" the king pin in the plate. "High hooking" occurs when backing your hitch into a trailer that is set too high, resulting in the lower flange of the king pin to wedge itself against the metal edge of the lower horseshoe piece or against the Lock Jaw Assembly. Damage to the Lock Jaw Assembly may result and not allow smooth operation of the closing mechanism.

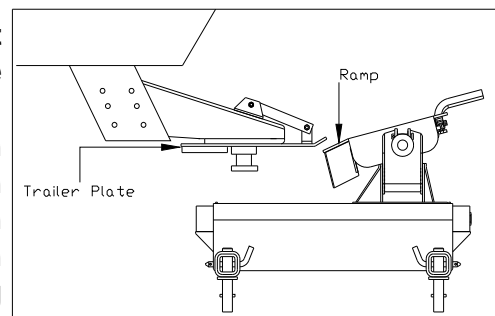

Figure 7

4. The 5th Wheel latch (**Figure 2**) must be in the open position. Lift and pull out on the Release Handle to open the Lock Jaw Assembly.

Caution: Damage will result should you attempt to hook up with the Lock Jaw Assembly in the closed position.

5. Back up the truck so that the king pin enters the center of the 5th Wheel Plate {A1} slot.
6. Make sure the Lock Jaw Assembly is completely seated around the king pin (**Figure 2**).
7. Be sure that the Release Handle (**Figure 2**) has fully returned to the closed position.

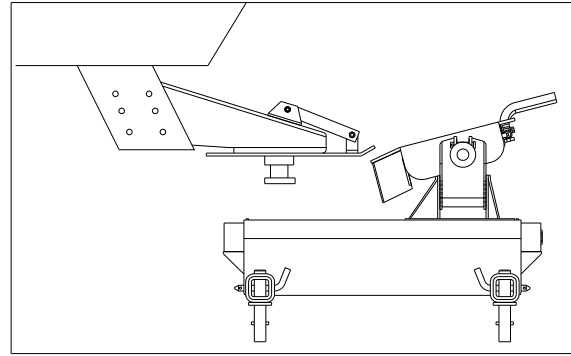

Figure 7

SAFETY CHECKS: Perform the following Safety Checks at this time:

1. Shine a light on the 5th Wheel Plate Lock Jaw Assembly making sure it has closed around the king pin.
2. Pull the Release Handle towards you without lifting it up. If the Lock Jaw Assembly is completely closed the Handle Catch will prevent you from being able to pull the Release Handle open.
3. Raise the trailer jack base plates just above the ground, lock your trailer brakes, then pull the tow vehicle slowly forward putting a strain on the trailer.
4. When you are assured that the trailer is safely hooked up, raise your trailer jacks into their full retracted position.

UNHITCHING

WARNING: Never perform any of the following actions while any part of a person is between the vehicle and the trailer.

1. Once you have the trailer located and are ready to unhitch, (**unhitching can only be accomplished when the truck and trailer are aligned within 16 degrees of each other see Fig. 6 page 6**), block the trailer wheels so it will not roll back or forward. Back into the blocked trailer slightly and set the parking brake while you are still in gear. This action will relieve pressure on the lock mechanism before attempting to release the latch mechanism.
2. Lower the trailer jacks to the point of just touching the ground but do not raise the trailer at this point.
3. Open the Lock Jaw Assembly by first lifting then pulling the Release Handle towards you. (**Figure 2**)
4. Lower the trailer jacks until the bottom of the king pin box is almost free of the top of the 5th Wheel Plate {A1}. Make certain that the bottom of the king pin is **not** so high that binding on the hitch Latch Catch would result.
5. After lowering the truck's tail gate, disconnect the trailer electrical cord and break-away switch cable, then pull forward.
6. As the king pin slides from the 5th Wheel Plate, notice that the locking mechanism remains open once the king pin is removed.

CAUTION: If it should be necessary to reposition your trailer, you must follow the hitching procedures to ensure the hitch is latched before moving the trailer. (pg. 6-7)

CAUTION: You may wish to keep the plate closed until you are ready to re-hitch to avoid injury or accidents to children or adults who attempt to operate the plate mechanism. **DO NOT ATTEMPT TO TRIP THE LOCK MECHANISM WITH YOUR HAND, USE A PROBE TO SIMULATE THE KING PIN.**

ADJUSTING THE TURNTABLE CAM ARM {C1}

This adjustment will need to be made periodically. If you are experiencing a bump or “clunk” when starting or stopping, or if the hitch is sliding up and down the way tubes when you are not hooked up to the trailer you can perform this adjustment to reduce the noise and keep the hitch in the forward towing position.

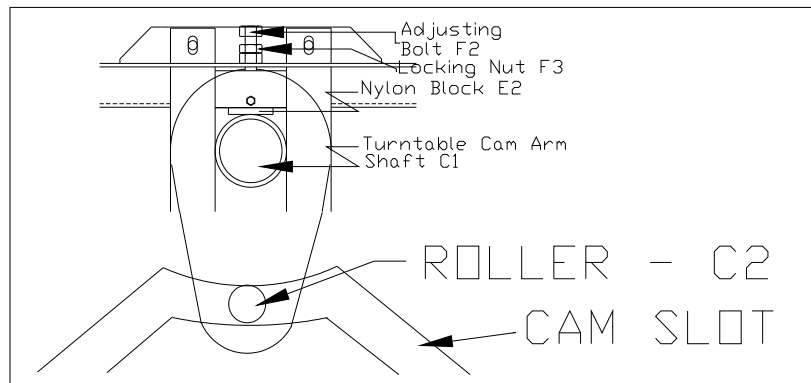

Figure 8

1. The Turntable Cam Arm Roller, {C2} needs to be kept snug against the rear edge of the of the Cam Slot **(Figure 8)**.
2. To adjust, loosen the Locking Nut {F3} located on the Adjusting Bolt {F2}, under the 5th Wheel Plate {A1} (on the side facing the front of your truck).
3. Hand tighten the Adjusting Bolt {F2} to remove excessive play from between the Nylon Block {E2} and the Turntable Cam Arm Roller {C2}. Turn the Adjusting Bolt {F2} 1/2 turn more. Then, while holding the Adjusting Bolt {F2} with one wrench, tighten the Locking Nut {F3} with another wrench.

WARNING: IF YOU OVER TIGHTEN THE ADJUSTING BOLT {F2}, YOU WILL COMPRESS THE NYLON BLOCK, AND MAY CAUSE DAMAGE TO THE HITCH.

ALTERNATE PLACEMENT OF JAM NUT

1. Remove 5/8 Adjusting bolt from Base
2. Remove jam nut from 5/8 bolt
3. Replace 5/8 bolt into base and thread the jam nut on to 5/8 bolt between bulkhead and stop block. This will allow easier access to the jam nut when tightening.

CHALLENGE vs. SOLUTION

Challenge	Solution
Cannot open the Release Handle.	You may have too much rearward pressure against the lock mechanism. Back your truck slightly to relieve pressure and continue the unhitching procedures.
Plate seems dry – Can I use a Teflon pad?	No. The Trailer Plate does not allow for any extra space for a pad. Since the turning action is no longer at the king pin, you will have minimal friction. A spray of silicone on the plate should suffice.
Trailer overhang is hitting the truck bed rails when the trailer and truck are at sharp angles.	Most trailer king pin boxes have height adjustment settings available to achieve the necessary clearance between the truck bed rails and the bottom of the trailer. Adjust accordingly.
The latch handle mechanism seems too stiff to operate.	Turn the plate upside-down and spray the locking mechanism with WD-40. Work the handle until it slides freely. If the problem persists, you may need to degrease and re-lube all working parts.
I have attempted to unhitch at an angle greater than 16 degrees, truck to trailer and the hitch will not release the King Pin.	Back into the King Pin, then using a probe, push the Lock Lever (Fig. 2) forward until the Lock Catch allows the Lock Jaw Assembly to rotate around the King Pin. Retract the trailer jacks and remove the wheel chocks. Maneuver the truck until it is lined up with in the 16 degree limit, see step 1 page 6. Perform unhitching steps 1 through 6 on page 7.
I need to have a professional evaluate my Super Glide.	Contact PullRite's Customer Service Dept. at 800/443-2307. Your needs will be assessed and resolved by PullRite or you will be directed to an authorized PullRite Service Center.

FREQUENTLY ASKED QUESTIONS

- **Can I pull other 5th wheel trailers with my SuperGlide hitch?**

Your SuperGlide hitch can only pull trailers equipped with the SuperGlide trailer plate. If you hook up to a trailer that does not have a trailer plate installed, there is nothing keeping the hitch in the forward towing position and the weight of the trailer will cause the head to turn and slam or “free fall” to the rear which can cause damage to the hitch and the king pin. We do not recommend locking the hitch in any way to keep it in the forward position.
- **Will a standard hitch be able to tow my trailer with the trailer plate installed?**

The trailer plate will need to be removed from the pin box before a standard fifth wheel hitch can tow your trailer. If the plate is not removed, the king pin will not rotate in the hitch and damage will result to the trailer plate. Part # 3336 is a conversion adapter that will allow a standard fifth wheel hitch to tow your trailer with the trailer plate installed. The adapter is used in conjunction with the fifth wheel plate, or “head” of the SuperGlide {A1}.
- **Are there plugs available to fill the holes drilled into my truck bed? (SuperRail)**

We do not have plugs at the present time. The contour of each application is different which makes it difficult to design a universal plug.
- **Is there a cover available for my SuperGlide hitch?**

We have a cover available for the 4100,4400, 3300. Purchase through your dealer.
- **Can I put a bed liner in my truck after the hitch is installed?**

SuperRail installation: It is actually better to install a spray in bed liner after the hitch is installed. This will allow the holes that were drilled to be covered. A plastic bed liner, or bed mat can be put in after the hitch is installed but you will have to match up the holes in the bed to the bed liner and cut the holes accordingly. Longer mounting posts may be required and can be ordered through your dealer or direct.
- **How much does my SuperGlide weigh?**

3100/317#, 4100/180#, 4400/215#, 3600/345#. The rails, posts, brackets, etc. can range from 50lbs. to 85 lbs.
- **Can I leave the hitch attached to my trailer and use the trailer jacks to lift the hitch out of the truck?**

Yes, you can use the trailer jacks to lift the hitch out of the truck. The hitch should not however be left hanging from the king pin. Once you have the hitch lifted out of the truck you should have a stand available to lower the hitch onto for storage.
- **Can I hook up or unhook at a 90 degree angle?**

Hooking up can only be accomplished when the truck and trailer are aligned within 16 degrees of each other. See pages 6-7 for more information on hooking up. Unhooking by pulling the release handle can only be accomplished when the truck and trailer are aligned within 16 degrees of each other. In emergency situations you can pull the clevis pins that attach the 5th wheel plate or “head” assembly to the rocker arm, lower your landing gear and raise the trailer up until the 5th wheel plate is free from the rocker arm. Back out from under the parked trailer. At that point you can pull the release handle, remove the head from the king pin and reattach it to your hitch with the clevis pins.
- **Can I use a Teflon disc or lube plate on the king pin plate?**

The king pin box and SuperGlide plate or “head” move together and since there is no friction, there is no need for any grease or a lube plate. Use of a Teflon disc or lube plate would cause the king pin to be short and problems hooking up will occur.



PARTS LIST



12k SuperGlide *(Part #3100)*

The following instructions provide valuable information regarding the various parts that comprise the 12K SuperGlide hitch.

Parts Listing for 12k SuperGlide

<u>Item #</u>	<u>Assemblies / Kits</u>	<u>Number</u>	<u>Qty.</u>	<u>Material</u>
A1	5th Wheel Plate Asm.	3601		
B1	Rocker Arm Assembly	3302		
C1	Turntable Cam Arm Asm.	3103		
C2	Roller	6901	1	
C3	Lock Washer	98200124	1	3/4" Lock Washer
C4	Jam Nut	98150142	1	3/4" Nut
D1	Turntable Ways (Set)	3104		
E1	Forward Shaft Stop Asm.	3305		
E2	Nylon Stop Block	33050105	1	
E3	Bolt	98410238	1	1/4"-20 x 1 3/4" HHCS, GRD 2
E6	Nut	98150209	1	1/4"-20 Nylock Nut
F1	Base Assembly	3106		
F2	Shaft Stop Set Screw	98010220	1	5/8"-11 x 2"
F3	Set Screw Jam Nut	98150141	1	5/8"-11 Hex Nut
G1	Base Rail Kit			
<p>The base rails are different for each application. Please see the Installation Instructions manual for a parts breakdown of the base rail kit. If you did not receive a copy of the Installation Instructions manual you can call PullRite customer service at 800-443-2307 to have a copy mailed to you.</p>				
H1	Hardware Kit	3310		
H2	Rocker Arm , Clevis Pin	98410111	2	1/2" x 2" Clevis Pin
H3	Clevis Pin Clip	98410127	2	#3 Cotter Pin
H4	Rocker Arm Pivot Bolt	98010147	1	3/4"-10 x 7" HHCS
H5	Pivot Bolt Lock Washer	98200124	1	3/4" Zinc Plated Split Lock Washer
H6	Pivot Bolt Hex Nut	98150131	1	3/4"-10 SAE Zinc Hex Nut
H7	Pivot Bolt Flat Washer	98250190	1	3/4" Flat Washer
H8	Rocker Arm Spring	35100001	1	16 GA Spring Steel
H9	Rocker Arm Spg Bolt	98010243	1	5/16"-18 x 3/4" Button Head Socket Cap Screw
H12	Way Tube Bolt	98010167	4	1/2"-13 x 1 1/2" HHCS Grd. 5
H13	Way Tube Flat Washer	98250180	4	1/2" Flat Washer
H14	Way Tube Lock Washer	98200142	4	1/2" Lock Washer
H15	Way Tube Nut	98150153	4	1/2" - 13 Hex Nut
J1	Universal Capture Plate Kit	3317 (*) denotes—	included in kit	
J2	*Capture Plate	331701	1	
K1	*Capture Plate Hardware Kit	331702	1	
K1	Capture Plate Hardware Kit	331702		
K2	Support Angle	35170002	2	3/16" x 1.5" x 1.5" Angle
K3	Support Bar	35170003	2	3/16" x 1" Flat
K4	Support "L" Bracket	35170004	2	3/16" x 1" Flat
K5	Support Bracket Bolts	98010243	8	5/16"-18 x 3/4" Button Head Cap Screw
K6	Support Bracket Nuts	98150202	8	5/16"-18 Nylock Nut
K7	Trailer Plate Mounting Bolts	98010240	10	1/4"-20 x 1 1/4" Flat Head Allen Screw
K8	Trailer Plate Mounting Nuts	98410255	10	1/4"-20 Nylock Nut

PARTS LIST ILLUSTRATION

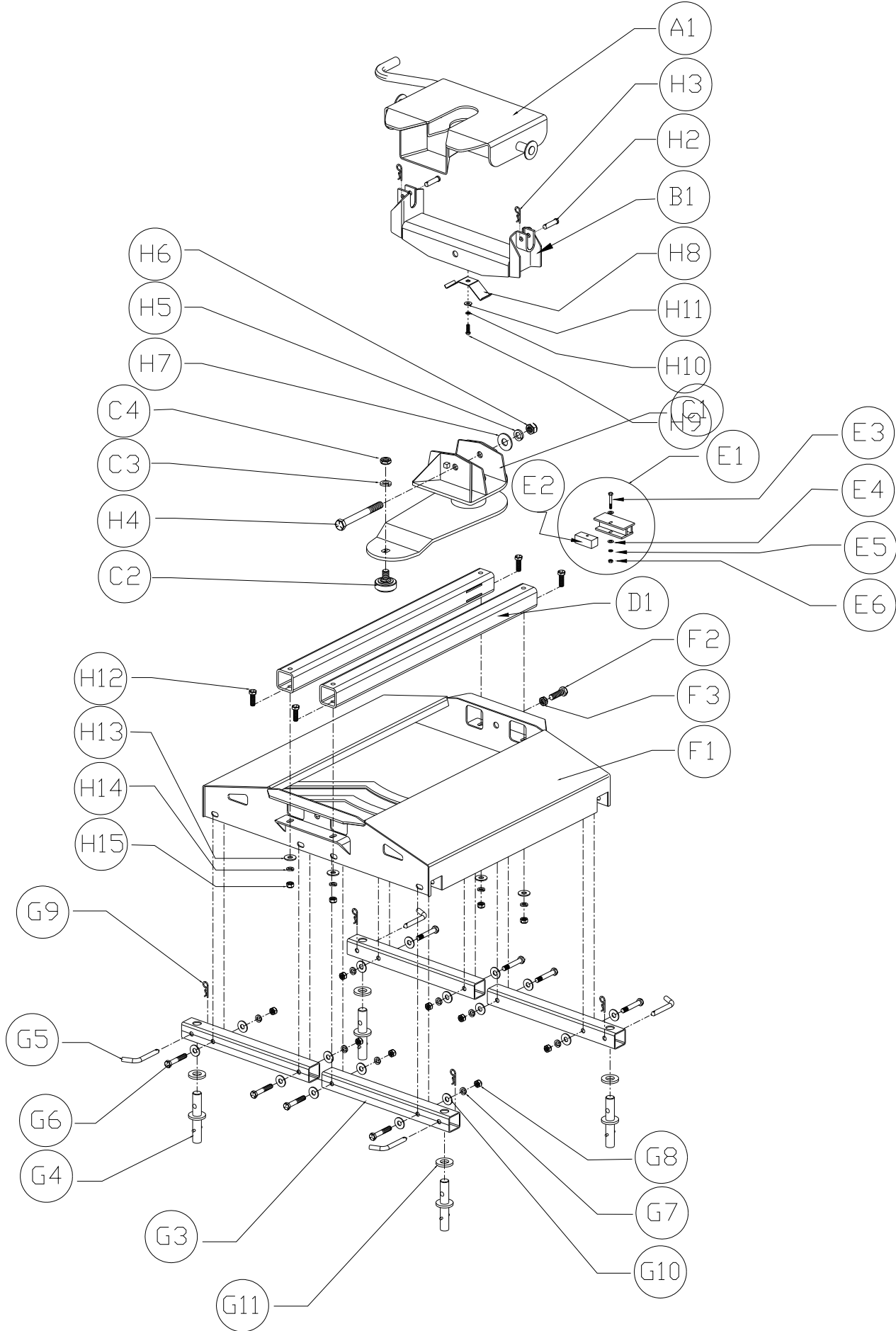



PARTS LIST



14k SuperGlide *(Part #4100)*

The following instructions provide valuable information regarding the various parts that comprise the 14K SuperGlide hitch.

Parts Listing For 14K SuperGlide

<u>Item #</u>	<u>Assemblies / Kits</u>	<u>Number</u>	<u>Qty.</u>	<u>Material</u>
A1	5th Wheel Plate Asm.	3601	1	
B1	Rocker Arm Asm.	4102	1	
C1	Turntable Cam Arm Asm.	4107	1	
C2	Roller	6901	1	
C3	Lock Washer	98200124	1	3/4" Lock Washer
C4	Jam Nut	98150142	1	3/4" Nut
D1	Turntable Ways (Set)	3304	1	2 1/2" Sq. 1/4" Wall Tubing
E1	Forward Shaft Stop Brkt Asm. 4105		1	
E2	Shaft Stop Set Screw	98010219	1	5/8"-11 x 2 1/2"
E3	Set Screw Jam Nut	98150141	1	5/8" -11 Hex Nut
E4	Forward Shaft Stop Asm. 3305		1	
E5	Nylon Stop Block	33050105	1	
E6	Bolt	98410238	1	1/4"-20 x 1 3/4" HHCS, GRD 2
E7	Nut	98150209	1	1/4"-20 Nylock Nut
F1	Base Assembly	4106	1	
G1	Base Rail Kit	3307	1	(* denotes—Can be ordered separately
G2	*Base Rail (Ea.)	33070001	2	2" SQ x 1/4" Wall Tubing
G3	*Base Rail Extension (Ea.)	33070002	4	1/4" HR A36
G4	*Mounting Post (Ea.)	330701	4	
G5	Base Rail Hinge Pins	08060001	8	1/2" CR RD
G6	Base Rail Bolt	98010183	4	1/2"-13 x 3 1/2" HHCS GRD 5
G7	Base Rail Lock Washer	98200142	4	1/2" Lock Washer
G8	Base Rail Nut	98150153	4	1/2" - 13 Hex Nut
G9	Clevis Pin Clip	98410127	8	#3 Cotter Pin
H1	Hardware Kit	4410	1	
H2	Rocker Arm , Clevis Pin	98410111	2	1/2" x 2" Clevis Pin
H3	Clevis Pin Clip	98410127	2	#3 Cotter Pin
H4	Rocker Arm Pivot Bolt	98010148	1	3/4" - 10 x 7" HHCS
H5	Pivot Bolt Lock Washer	98200124	1	3/4" Zinc Plated Split Lock Washer
H6	Pivot Bolt Hex Nut	98150131	1	3/4" -10 SAE Zinc Hex Nut
H7	Rocker Arm Spring	35100001	1	16 GA Spring Steel
H8	Rocker Arm Spg Bolt	98010243	1	5/16"-18 x 3/4" Button Head Socket Cap Screw
H9	Spring Bolt Lock Wash	98200159	1	5/16" Zinc Split Lock Washer
H10	Spring Flat Washer	98250160	1	5/16"-18 Flat Washer
H11	Way Tube Bolt	98010159	7	1/2"-13 x 1" Carriage Bolt Grd. 5
H12	(Flat Washer No Longer Used In This Application)			
H13	Way Tube Flange Nut	98150201	7	1/2" - 13 Flange Nut

PARTS LIST ILLUSTRATION

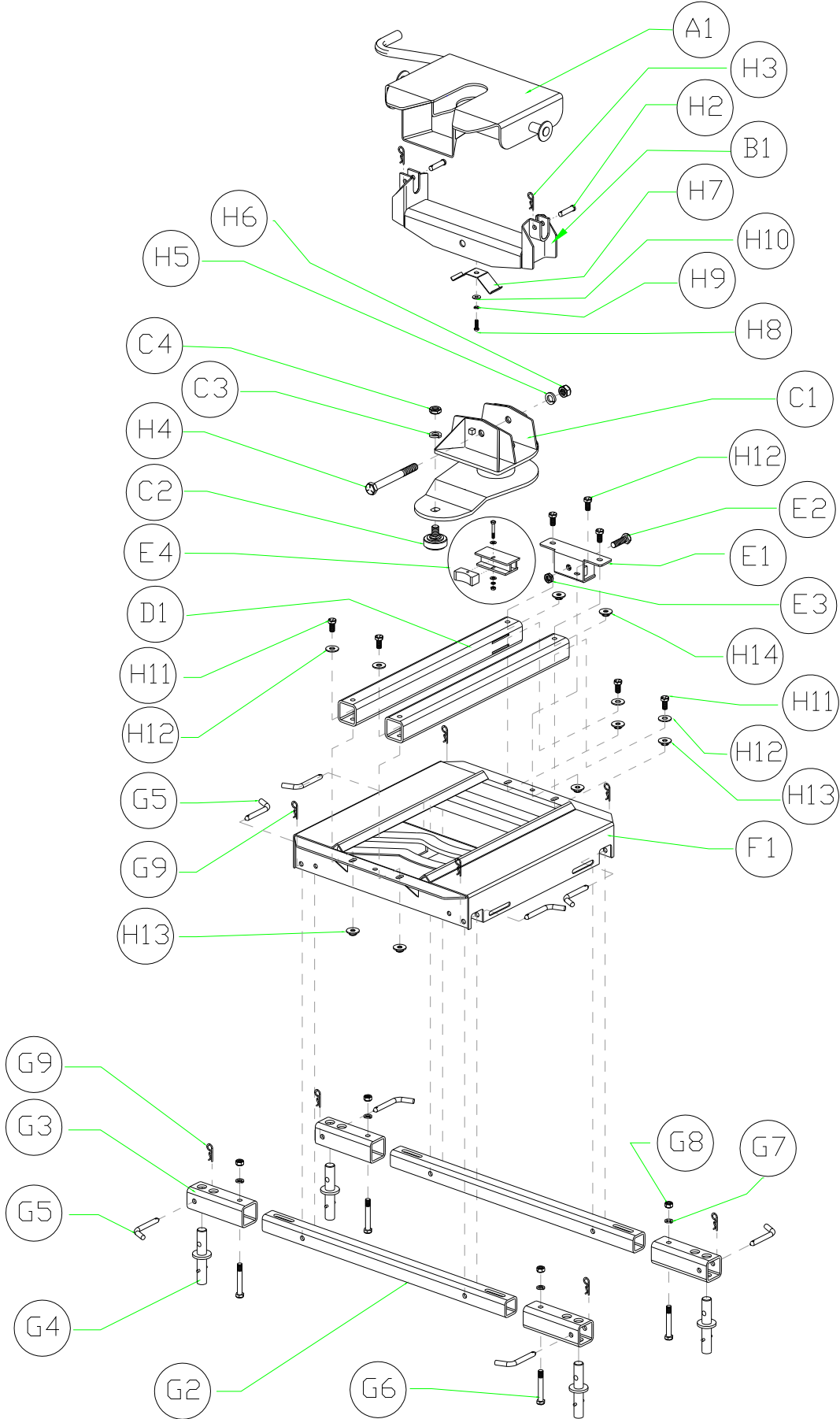



PARTS LIST



18k SuperGlide *(Part #4400)*

The following instructions provide valuable information regarding the various parts that comprise the 18K SuperGlide hitch.

Parts Listing For 18K SuperGlide

<u>Item #</u>	<u>Assemblies / Kits</u>	<u>Number</u>	<u>Qty.</u>	<u>Material</u>
A1	5 th Wheel Plate Asm.	3601	1	
B1	Rocker Arm Asm.	4402	1	
C1	Turntable Cam Arm Asm.	4404	1	
C2	Roller	6901	1	
C3	Lock Washer	98200124	1	3/4" Lock Washer
C4	Jam Nut	98150142	1	3/4" Nut
D1	Turntable Ways (Set)	3304	1	2 1/2" Sq. 1/4" Wall Tubing
E1	Forward Shaft Stop Asm.	3305		
E2	Nylon Stop Block	33050105	1	
E3	Bolt	98410238	1	1/4"-20 x 1 3/4" HHCS, GRD 2
E6	Nut	98150209	1	1/4"-20 Nylock Nut
F1	Base Assembly	4406	1	
F2	Shaft Stop Set Screw	98010219	1	5/8"-11 x 2 1/2"
F3	Set Screw Jam Nut	98150141	1	5/8" -11 Hex Nut
G1	Base Rail Kit	3307	1	(*) denotes—Can be ordered separately
G2	*Base Rail (Ea.)	33070001	2	2" SQ x 1/4" Wall Tubing
G3	*Base Rail Extension (Ea.)	33070002	4	1/4" HR A36
G4	*Mounting Post (Ea.)	330701	4	
G5	Base Rail Hinge Pins	08060001	8	1/2" CR RD
G6	Base Rail Bolt	98010183	4	1/2"-13 x 3 1/2" HHCS GRD 5
G7	Base Rail Lock Washer	98200142	4	1/2" Lock Washer
G8	Base Rail Nut	98150153	4	1/2" - 13 Hex Nut
G9	Clevis Pin Clip	98410127	8	#3 Cotter Pin
H1	Hardware Kit	3310	1	
H2	Rocker Arm , Clevis Pin	98410111	2	1/2" x 2" Clevis Pin
H3	Clevis Pin Clip	98410127	2	#3 Cotter Pin
H4	Rocker Arm Pivot Bolt	98010147	1	3/4" - 10 x 7 1/2" HHCS
H5	Pivot Bolt Lock Washer	98200124	1	3/4" Zinc Plated Split Lock Washer
H6	Pivot Bolt Hex Nut	98150131	1	3/4" -10 SAE Zinc Hex Nut
H7	Rocker Arm Spring	35100001	1	16 GA Spring Steel
H8	Rocker Arm Spg Bolt	98010243	1	5/16"-18 x 3/4" Button Head Socket Cap Screw
H9	Spring Bolt Lock Wash	98200159	1	5/16" Zinc Split Lock Washer
H10	Spring Flat Washer	98250160	1	5/16"-18 Flat Washer
H11	Way Tube Bolt	98050119	4	1/2"-13 x 4 " Carriage Bolt Grd. 5
H12	Way Tube Flange Nut	98150201	4	1/2"-13 Flange Nut

PARTS LIST ILLUSTRATION

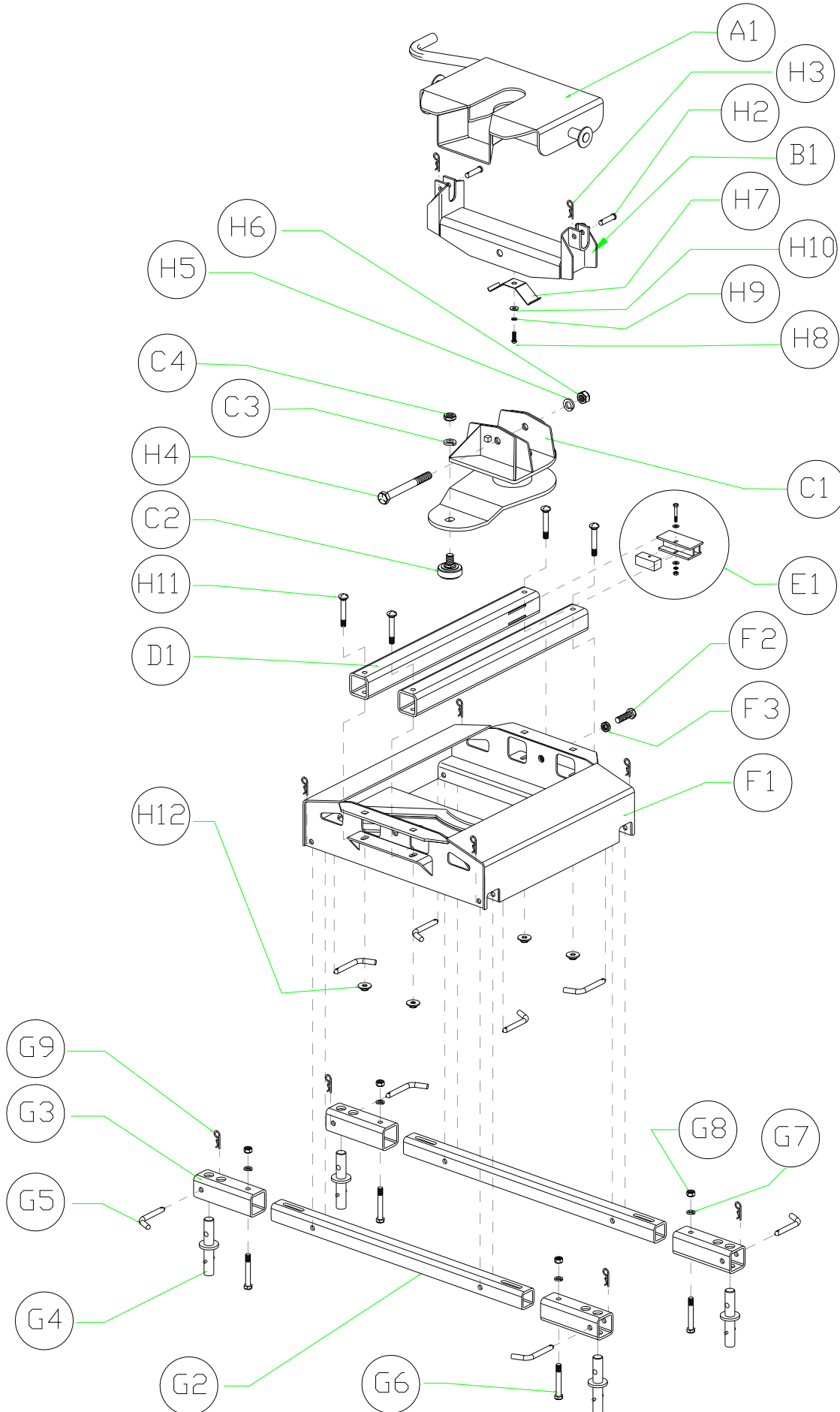



PARTS LIST



24k SuperGlide *(Part #3600)*

The following instructions provide valuable information regarding the various parts that comprise the 24K SuperGlide hitch.

Parts Listing For 24K SuperGlide

<u>Item #</u>	<u>Assemblies / Kits</u>	<u>Number</u>	<u>Qty.</u>	<u>Material</u>
A1	5th Wheel Plate Asm.	3601		
B1	Rocker Arm Asm.	3502		
C1	Turntable Cam Arm Asm.	3603		
C2	Roller	6901	1	
C3	Lock Washer	98200124	1	3/4" Lock Washer
C4	Jam Nut	98150142	1	3/4" Nut
D1	Turntable Ways (Set)	3604		
E1	Forward Shaft Stop Asm.	3606		
E2	Nylon Stop Block	33050105	1	
E3	Bolt	98410238	1	1/4"-20 x 1 3/4" HHCS, GRD 2
E6	Nut	98150209	1	1/4"-20 Nylock Nut
F1	Base Assembly	3605		
F2	Shaft Stop Set Screw	98010128	1	3/4"-10 x 2 1/2" HHCS
F3	Set Screw Jam Nut	98150131	1	3/4" -10 Hex Nut
H1	Hardware Kit	3610		
H2	Rocker Arm , Clevis Pin	98410111	2	1/2" x 2" Clevis Pin
H3	Clevis Pin Clip	98410127	2	#3 Cotter Pin
H4	Rocker Arm Pivot Bolt	140501	1	1" – 8 x 9 1/2" HHCS
H5	Pivot Bolt Lock Washer	98200115	1	1" Zinc Plated Split Lock Washer
H6	Pivot Bolt Hex Nut	98150120	1	1" – 8 SAE Zinc Hex Nut
H8	Rocker Arm Spring	35100001	1	16 GA Spring Steel
H9	Rocker Arm Spg Bolt	98010243	1	5/16"-18 x 3/4" Button Head Cap Screw
H10	Spring Bolt Lock Wash	98200159	1	5/16" Zinc Split Lock Washer
H11	Spring Flat Washer	98250160	1	5/16"-18 Flat Washer
H12	Way Tube Bolt	98010167	4	1/2"-13 x 1 1/2" HHCS GRD 5
H13	Way Tube Flat Washer	98250160	4	1/2" Flat Washer
H14	Way Tube Lock Washer	98200142	4	1/2" Lock Washer
H15	Way Tube Nut	98150153	4	1/2"-13 Hex Nut
J1	Trailer Plate Kit	3317 (*) denotes– included in Kit		
J2	*Trailer Plate	331701	1	
K1	*Trailer Plate Hdw. Kit	331702	1	
K1	Trailer Plate Hardware Kit	331702		
K2	Support Angle	35170002	2	3/16" x 1.5" x 1.5" Angle
K3	Support Bar	35170003	2	3/16" x 1" Flat
K4	Support "L" Bracket	35170004	2	3/16" x 1" Flat
K5	Support Bracket Bolts	98010243	8	5/16"-18 x 3/4" Button Head Cap Screw
K6	Support Bracket Nuts	98150202	8	5/16" –18 Nylock Nut
K7	Trailer Plate M Bolts	98010240	10	1/4" –20 x 1 1/4" Flat Head Allen
K8	Trailer Plate M Nut	98410255	10	1/4" – 20 Nylock Nut

PARTS LIST ILLUSTRATION

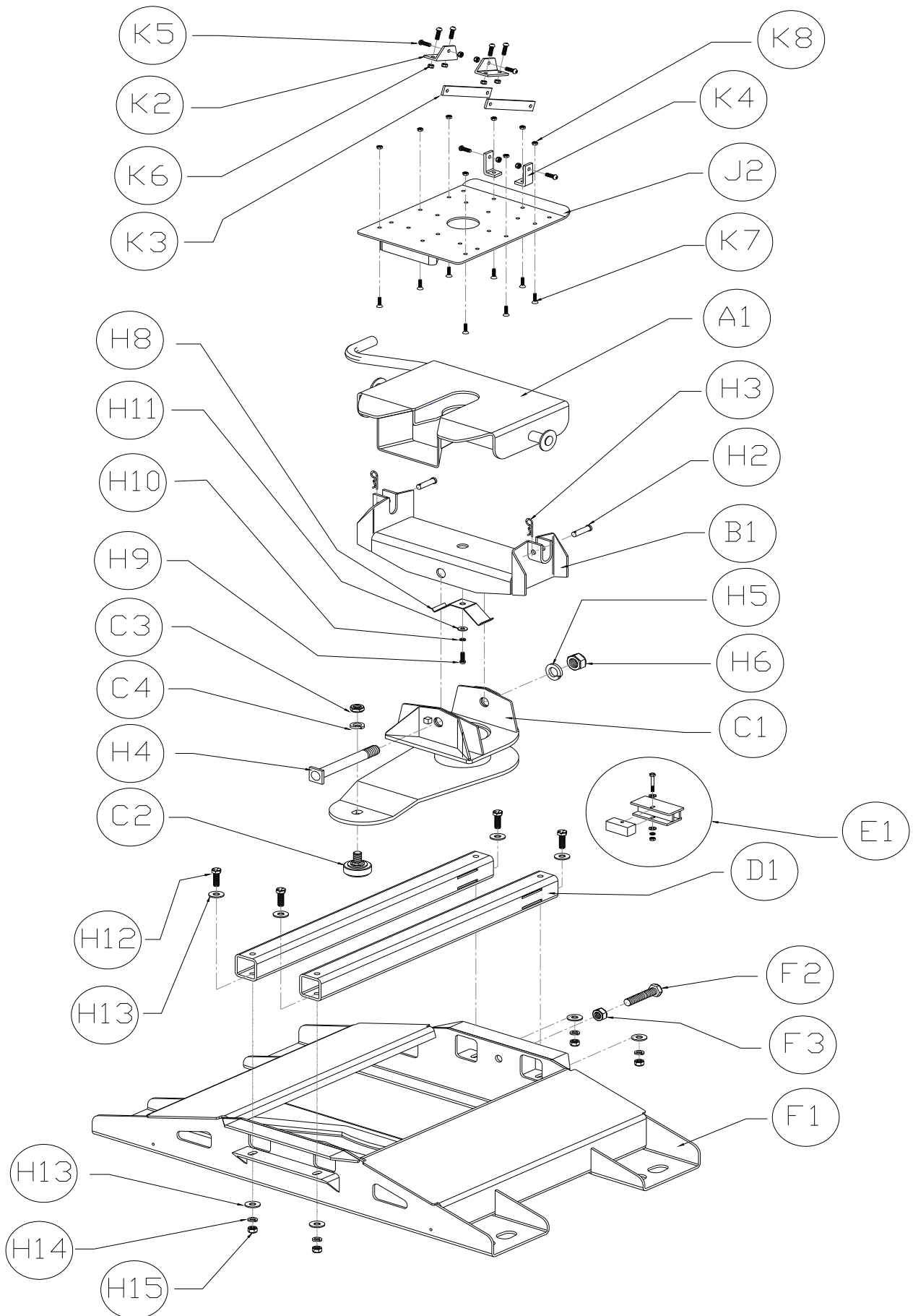



3336 Conversion Adapter Owner / Operator Instructions

This Adapter will allow your trailer to be pulled by a non-SuperGlide hitch when used in conjunction with the head of your SuperGlide.

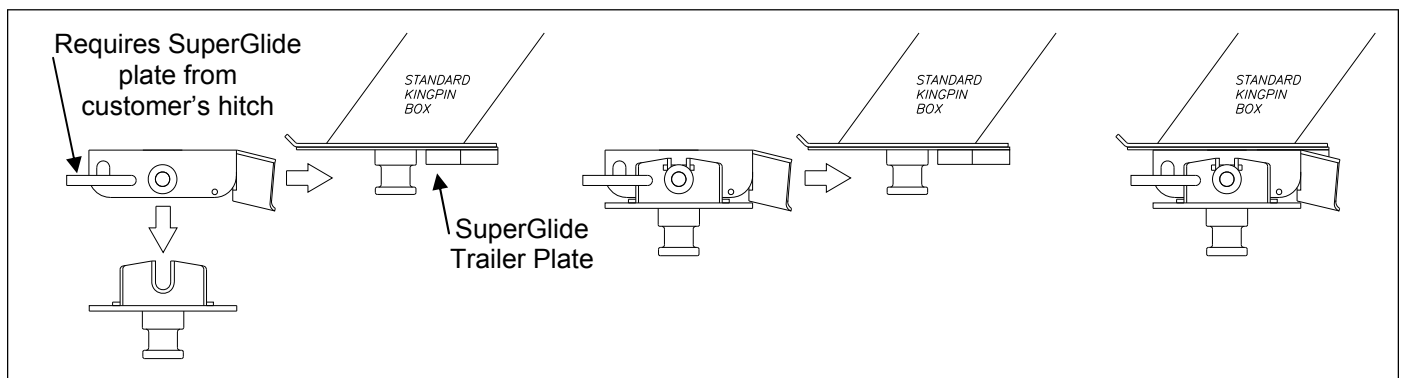

Instructions:

1. Remove the 5th wheel plate (part# 3601) from the SuperGlide hitch by removing the 1/2" x 2" clevis pins and clips.
2. Slide the **Conversion Adapter** onto the 5th wheel hitch of the non-SuperGlide hitch.
3. Insert the Super 5th plate (your SuperGlide hitch head) in the **Conversion Adapter** cradles, and secure with the 1/2" x 2" clevis pins and clips.
4. Hook up to the trailer conventionally.

NOTE: Hook-up must be performed in straight line.



PULLIAM ENTERPRISES, INC.
13790 East Jefferson Blvd.
Mishawaka, IN 46545
(574) 259-1520 or (800) 443-2307
info@pullrite.com • www.pullrite.com

FIVE YEAR LIMITED WARRANTY

PULLIAM ENTERPRISES, INC. hereinafter referred to as “**PULLIAM**”, warrants to the first retail owner only, this PullRite towing system to be free from defects in materials and workmanship for a period of five (5) years or 31,068 miles (50,000 km) after the installation on purchaser’s vehicle, whichever occurs first.

To validate this warranty, the first retail owner must mail the provided warranty card to **PULLIAM** within ten (10) days after installation of said towing system on his vehicle.

The owner is responsible for all normal and preventive maintenance described in the Owner’s Instructions.

If any defect occurs which the owner believes is covered by this warranty within said five (5) year period, the owner shall contact **PULLIAM** immediately, either in writing or by telephone call, Attention Customer Service Department. The owner will be instructed to return the hitch at his expense either to an authorized PullRite dealer or to **PULLIAM** to repair or replace any parts necessary to correct defects in material or workmanship.

Repair or replacement shall be at the sole option of **PULLIAM** and shall be completed by or on behalf of **PULLIAM** free of charge for materials and labor. This warranty gives you specific legal rights, and you may also have other right’s which vary from state to state.

THIS WARRANTY SPECIFICALLY EXCLUDES EACH OF THE FOLLOWING:

1. Defects in the product resulting from misuse, neglect, accident, loading beyond the vehicle’s capacity, failure to comply with instructions contained in the Owner’s Instruction or unauthorized repairs, replacements, alterations or modifications. “Unauthorized repair, replacements, alterations” are those made without **PULLIAM’S** prior knowledge and consent.
2. Any incidental or consequential damage including, but not limited to, loss of use of the vehicle, towing charges, vehicle rental, loss of time, inconvenience, travel, gasoline, lodging and telephone expenses, loss of revenue and damages on account of personal injury and property damage. (Some states do not allow the exclusion or limitation of incidental or consequential damages, so these limitations may not apply to you).
3. Repairs or replacements of defects in any PullRite towing system, or part thereof, installed on any vehicle which has been rented, leased or used for any commercial purpose.
4. Any representation, warranty of undertaking made by any dealer or third party beyond the scope of the warranty herein expressed.
5. Any problem resulting in normal deterioration due to wear or exposure.

TO THE EXTENT PERMITTED BY LAW, IMPLIED WARRANTIES OF MERCHANTABILITY AND FITNESS FOR A PARTICULAR PURPOSE ARE LIMITED IN DURATION TO FIVE YEARS FROM THE DATE OF INSTALLATION ON THE FIRST OWNER’S VEHICLE. (SOME STATES, HOWEVER, DO NOT ALLOW LIMITATIONS AS TO DURATION OF IMPLIED WARRANTY, SO THOSE LIMITATIONS MAY NOT APPLY TO YOU)

PULLRITE TRAILER TOWING SYSTEMS

MANUFACTURED BY:

PULLIAM ENTERPRISES, INC.
13790 East Jefferson Blvd.
Mishawaka, IN 46545
(574) 259-1520 or (800) 443-2307
info@pullrite.com • www.pullrite.com





WARRANTY REGISTRATION

Failure to complete this form may cause an invalidation of the manufacturer's warranty.

FULL NAME *(please print)*:

ADDRESS

CITY, STATE & ZIP CODE

PHONE

PURCHASE DATE

NAME OF DEALER WHERE PURCHASED

PURCHASE PRICE

CITY & STATE

WHAT INFLUENCED YOUR PURCHASE?

- Advertisement
- Dealer Recommendation
- Product Video
- Manufacturer's Reputation
- Friend
- Other *(please specify)*:

PLEASE CHECK ITEM(S) PURCHASED:

- 12k SuperGlide
- 14k SuperGlide
- 18k SuperGlide
- 24k SuperGlide
- 15.5 Super 5th
- 20.5 Super 5th
- 25.5 Super 5th
- 25.5 Low Profile Super 5th
- 70°, 10k PullRite
- 90°, 10k PullRite
- 70°, 20k PullRite
- 90°, 20k PullRite
- Telescoping PullRite
- Other *(please specify)*:

COMMENTS:

Complete and mail to: Pulliam Enterprises, Inc. , 13790 East Jefferson Blvd., Mishawaka, IN 46545 or register online at www.pullrite.com